

SIMPO HV

Installation and Operating Manual

(EN)

ZYC ENERGY
ZERO YOUR CARBON

Version: V2.6
Released Date: 2025-03-20



Contents

1 Introduction	1
2 Glossary	1
3 Safety	1
3.1 Intended Use.....	1
3.2 Battery Module Leakage	2
3.3 Fire	2
3.4 Handling	2
3.5 Storage.....	2
3.6 Transportation.....	2
4 Product Information	3
4.1 SIMPO HV Package.....	3
4.2 Different Functional Area On BMS	3
4.3 Specifications.....	4
5 Installation	4
5.1 Requirement For Installation Location	4
5.2 Tools.....	5
5.3 Place The Base.....	5
5.4 Position of Fixing Part.....	5
5.5 Power Cables Crimping	6
5.6 Fix To The Wall.....	6

5.7 Cables Connection	7
5.8 Communication With Different Inverter Models	8
6 Human Machine Interface(HMI)	9
7 Parallel Multiple Towers	11
8.Commissioning.....	12
8.1 Air Switch	12
8.2 Start Up	12
8.3 System Shut Down	12
8.4 Charging and Discharging.....	12
9 Connect to the Internet&ZYC portal&ZYC Assist	13
10 Extension.....	14
11 Troubleshooting	14
12 Maintenance and Storage	14
13 Disposal of SIMPO HV	14
14 Compatible Inverter	15
15 Date of Manufacture	15
16 Warranty	15
17 Contact Us.....	16

1 Introduction

SIMPO HV is a new high voltage battery with 50Ah capacity, 64V voltage and 3.2kWh energy. Designed by ZYC ENERGY. The specifications can be found in *4.5 Specification*.

SIMPO HV has a total of eight models, which are SIMPO HV 6.4, SIMPO HV 9.6, SIMPO HV 12.8, SIMPO HV 16, SIMPO HV 19.2, SIMPO HV 22.4, SIMPO HV 25.6 and SIMPO HV 28.8. This installation manual applies to all eight models.

Up to 9 SIMPO HV can be connected in series in a single tower controlled by 1 BMS. Up to 8 towers can be connected in parallel at the same time. The energy range is from 6.4kWh to 230.4kWh and can fit either residential or C&I use.

The design used in SIMPO HV makes it easy and quick to install, with the whole system taking up only 70% of the floor space of comparable products.

The installed system does not require any commissioning or configuring and can start working as soon as the system is built up.

The paralleled towers are hot-swappable, which ensures that the system can be operated even when one of the towers fails.

The unique BIC design makes the communication more stable and reduces the system stop caused by communication failure.

2 Glossary

Terms	Full Name
BESS	Battery Energyn Storage System
BMS	Battery Management System
BMU	Battery Management Unit
BIC	Battery Information Collector
BCU	Battery Control Unit
SOC	State of Charge
SOH	State of Health
LFP	Lithium iron phosphate(LiFePO ₄)

3 Safety

When installing, commissioning, operating and maintaining the product, the safety requirements in the manual should be strictly observed. Incorrect operation or work may lead to damage to the product

and other properties or injury or death of the operator or third parties.

When fixing the product with screws or other parts, use the correct tool and reinforce it with the torque indicated in the manual or on the label of the product, otherwise the product may be unstable or damaged.

When using different tools, master the tools in advance to prevent the installer from being injured due to improper handling.

Please read this manual thoroughly before installation to ensure proper and safe installation and use of the product.

Warning And Caution

1. Installers and users are obliged to familiarise themselves with this manual.
2. Power Cables and plugs have high voltage from the battery, be careful when wiring.
3. Ensure that a fire extinguisher is in place prior to installation and use.
4. Installation and operation must be carried out by qualified personnel and the system must be installed in restricted access areas.
5. The battery module is with certain weight, it is better to be installed by at least two personnel. With the help of tools if necessary.
6. The battery terminals cannot not be touched directly by hands.
7. Users must wait 3 seconds when the battery is unstacked.

3.1 Intended Use

SIMPO HV is designed for both residential and C&I use. It is a high-voltage lithium-ion battery storage system that operates with compatible inverters in grid-connected, off-grid and backup modes.

The BMS design allows SIMPO HV to be connected to the internet for remote monitoring and firmware upgrades.

The IP65 enclosure design allows SIMPO HV to be used both indoors and outdoors, but please make sure that it is only used in connection with a matched inverter.

SIMPO HV is not suitable for powering life-sustaining medical equipment.

Please ensure that a battery system power failure

will not cause personal injury.

3.2 Battery Module Leakage

Stop using damaged battery immediately and dispose of it in the correct place or return it to a professional.

- Damage to the battery may result in leakage of electrolyte, and lifting into the electrolyte may cause consequences such as breathing difficulties, skin irritation and chemical burns. When the following conditions occur, the following guidelines should be followed promptly.
- Eye contact Rinse gently with running water for at least 15 minutes and seek medical help promptly.
- Skin contact Rinse under running water for more than 15 minutes, remove any contaminated clothing and seek medical attention.
- Inhalation or ingestion Leave the contaminated area and seek medical assistance

3.3 Fire

Fire may occur with the battery if the battery is too close to a flame or the temperature of the environment is unusually high. Carbon monoxide, carbon dioxide, and other gases and emit smoke may occur if the battery is on fire. Empty the fire area in a timely manner, use a full-face self-contained breathing apparatus (SCBA) with full protective gear during fire fighting and use a dry chemical fire extinguisher to cool and extinguish the battery to prevent the fire from spreading

3.4 Handling

- Installers should be cautious during installation to prevent damage to the battery.
- If the battery has been damaged before installation, including but not limited to shell damage, terminal port damage. Please do not use and contact us.
- Protect the battery from being damaged during transporting and handling.

- Do not clean the battery with corrosive solution or stuff or allow foreign objects to enter the battery.
- Do not unplug any cables directly while the battery is in operation.
- Do not use the battery together with batteries of other brands or types.
- Do not short circuit the battery modules.
- Avoid subjecting the battery to external forces, such as being dragged on the ground, or having heavy objects placed on the battery.

3.5 Storage

- Do not store the battery in an environment that is exposed to direct sunlight or high humidity, and ensure that it is kept away from heat and water.
- Batteries stored for long periods of time (≥ 6 months) should be charged periodically to prevent irreversible damage caused by low battery power.
- If the battery is stored for a long period of time, the ambient temperature should be maintained at about 25°C. If the battery is only stored for a short period of time, the ambient temperature should also be ensured to be between 0°C and 35°C.
- Do not store the batteries in a high humidity environment.

3.6 Transportation

Batteries should be shipped with the terminals covered to prevent contact with metal objects and short circuits during transport. Our batteries are discharged to a certain state of charge before shipment to you in order to comply with international transport regulations.

Where possible, batteries should be shipped in the manufacturer's arrangement, horizontally and secured. Prevent shipping vertically if possible, and with a limit on the number of batteries stacked on top of each other. Do not place heavy objects on the battery to prevent damage to the battery

4 Product Information

4.1 SIMPO HV Package

Battery Module Box

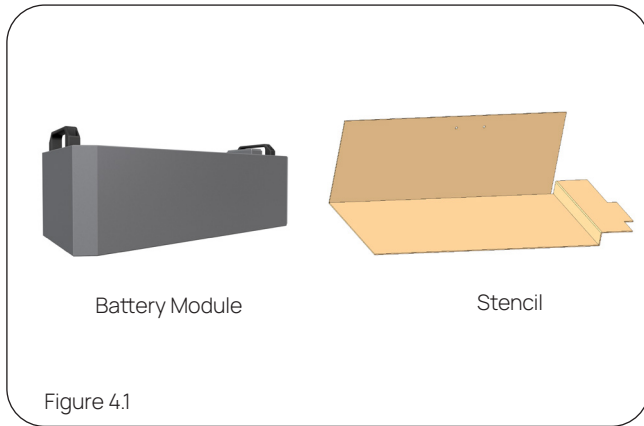

BMS&Base Box

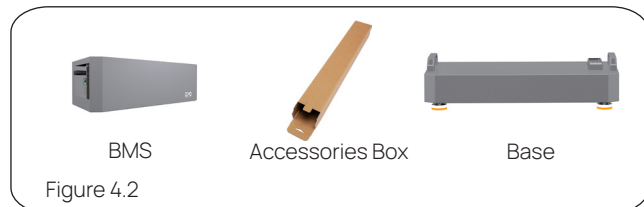

Accessories Included

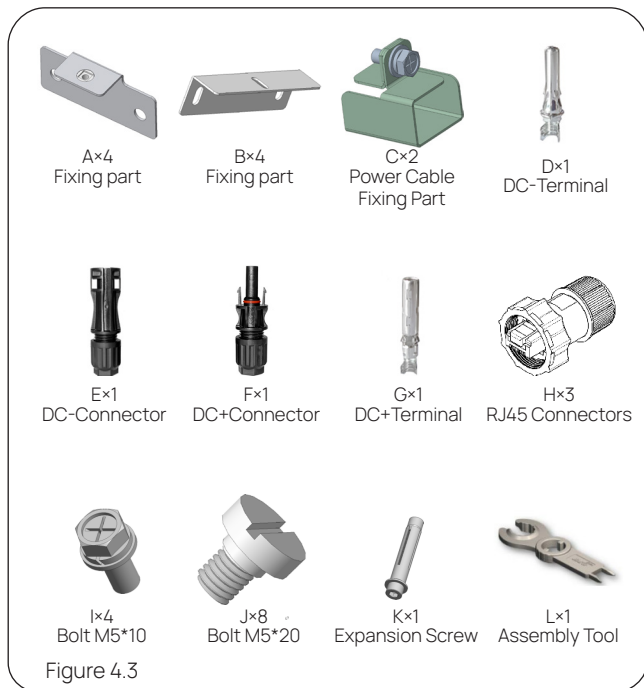

Extra Accessories

The parts below are not included in SIMPO HV package but necessary for connecting to the inverter.

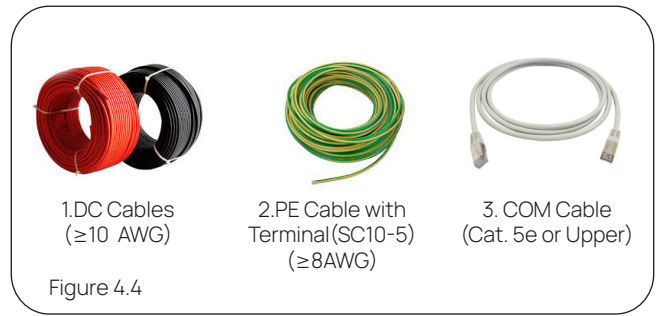

1.DC Cables with Terminal

Cables of 8/10 AWG is recommended to meet the need of SIMPO HV.or Copper CSA(Cross Sectional Area): $5\text{mm}^2 \leq S \leq 9\text{mm}^2$

Determine the cable size according to your system.

2.PE Cable(CSA≥25mm²)with Terminal(SC35-6)

3.Communication cable with shield(Cat 5 or higher)

4.2 Different Functional Area On BMS

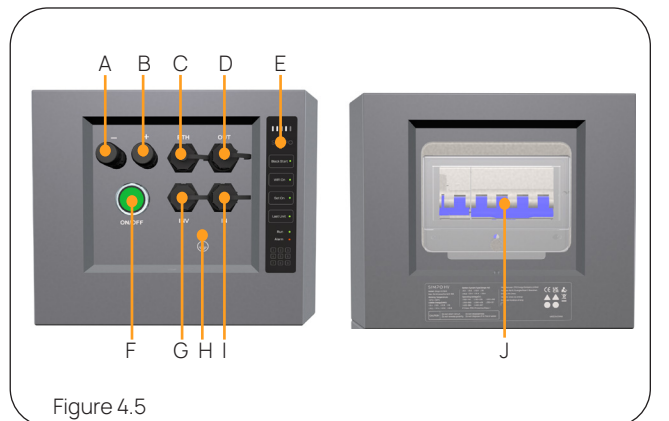

Letter	Lable	Function
A	-	DC-
B	+	DC+
C	ETH	Ethernet
D	OUT	Com Out
E	HMI	Human Machine Interface
F	ON/OFF	ON/OFF
G	INV	Inverter Com
H	PE	PE Connection
I	IN	COM In
J	/	Air Switch

4.3 Specifications

SIMPO HV	Specifications							
Module Data	3.2kWh, 64V, 36.4kg							
SIMPO HV Modules	SIMPO HV 6.4	SIMPO HV 9.6	SIMPO HV 12.8	SIMPO HV 16.0	SIMPO HV 19.2	SIMPO HV 22.4	SIMPO HV 25.6	SIMPO HV 28.8
Module Quantity in Tower	2	3	4	5	6	7	8	9
Nominal Capacity(kWh)	6.4	9.6	12.8	16.0	19.2	22.4	25.6	28.8
Usable Capacity(kWh)	6.4	9.6	12.8	16.0	19.2	22.4	25.6	28.8
Rated DC Power (W)	6400	9600	12800	16000	19200	22400	25600	28800
Nominal Voltage(V)	128	192	256	320	384	448	512	576
Operating Voltage Range(V)	102~148	153~222	204~296	255~370	306~444	357~518	408~592	459~666
Max Charge/Discharge Current (A)	30							
Peak Current (5s) (A)	45							
Depth of Discharge	100%							
Weight(kg)	92.5	128.9	165.3	201.7	238.1	274.5	310.9	347.3
Dimension_W(mm)	610							
Dimension_D(mm)	240							
Dimension_H(mm)	670	860	1050	1240	1430	1620	1810	2000
Round-trip Efficiency	≥96%							
Charging Temp Range (°C)	-8 ~ 50							
Discharging Temp Range (°C)	-20 ~ 50							
Operating Humidity	Up to 95% (Non-condensing)							
IP Rating	IP65							
Communication	CAN / Modbus RS485							
Altitude (m)	≤3000							
Warranty	10 Years 70% SOH or 9.92MWh Energy Throughput							
Scalability (Parallel)	1 ~ 8 Towers							
Manufacture Country	China							
Certificate	UN38.3 / CE / IEC62619 / VDE2510-50							

5 Installation

This session provides important information and detailed guidelines for installing the product to ensure a safe and smooth installation process. Installation should be well considered and all the specification of the battery should be understood to determine a suitable location and way for the installation.

5.1 Requirement For Installation Location

SIMPO HV can be installed both indoor and outdoor. The location of installation should be suitable for safe operation and long-term use. The installation

location should be chosen to meet the following conditions as much as possible:

- The ambient temperature should be between -20°C and $+50^{\circ}\text{C}$.
- The installation environment is free of flammable and explosive materials. Do not expose the battery to high temperatures or any sources of heat such as fire, transformers and heaters. The distance between the battery and heat source should be at least 5 meters.
- Avoid direct sunlight, rain and snow. Please install batteries indoor or outdoor under roof.
- Well-ventilated with good air circulation for indoor and outdoor use.

- e) Natural ventilation needs to be achieved for indoor installation, the indoor ventilation system should ensure air circulation .
- f) The ambient humidity should be between 5-95%
- g) The altitude of the installation location should be less than 3000 meters.
- h) Keep away from children or pets to prevent injury by accident.

5.2 Tools

Tools below are necessary for the installation of SIMPO HV. Make sure you are well prepared before starting.

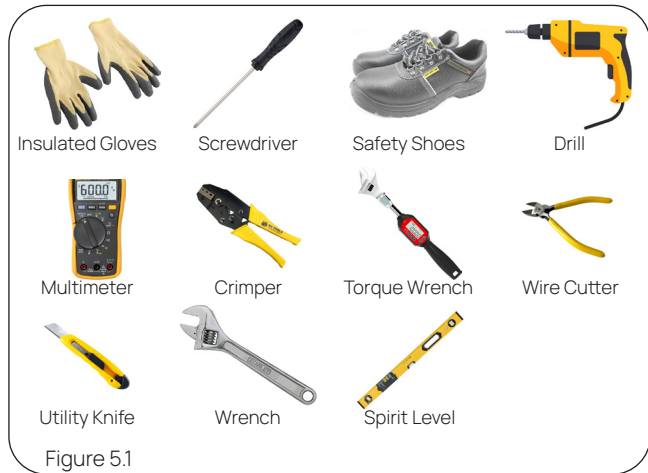

5.3 Place The Base

The base designed for SIMPO HV is adjustable via four bolts for uneven ground. Customer can adjust the height of the base to meet different needs.

The location of SIMPO HV installation should be suitable for safe operation and long-term use. Place the base on solid ground to prevent the system from collapsing or tilting during use.

As SIMPO HV should be fixed to the wall, location selected should be against the wall, and keep the distance between the base and the wall between 27 and 34 mm.

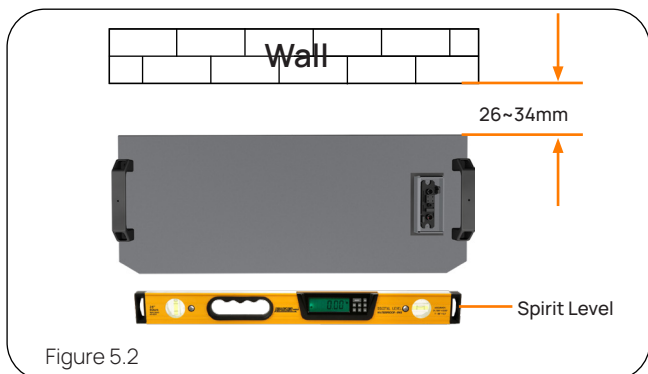

When multiple towers are connected in parallel, the minimum spacing between towers should be maintained.

Keep minimum 300mm between towers.

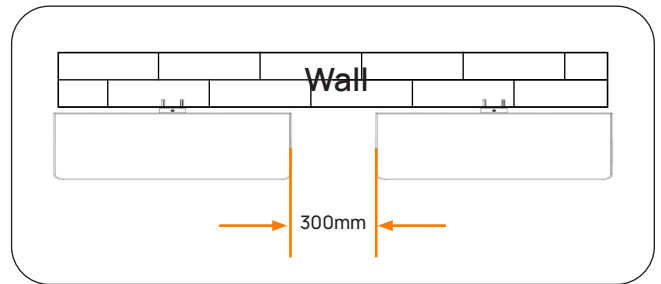

5.4 Position of Fixing Part

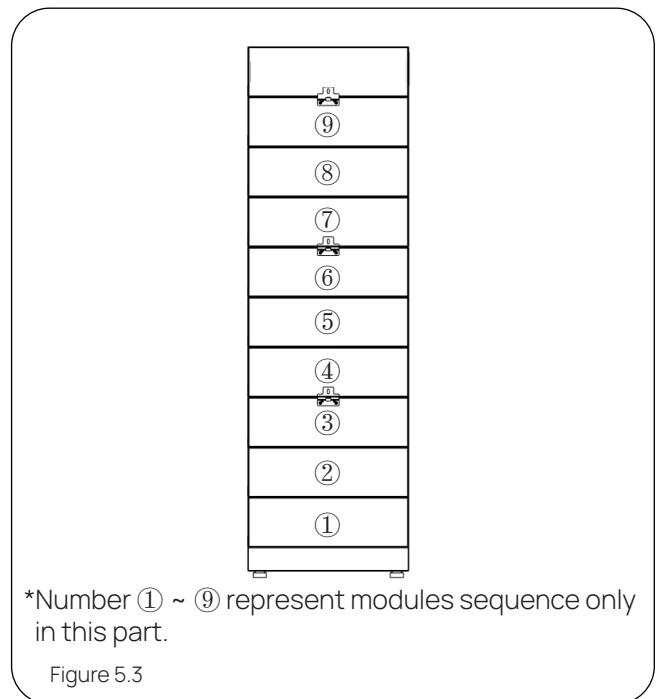

Stacking of modules, bases and BMS:

After confirming the position of the base, the modules are stacked on the base and then the BMS is placed on the top of the tower.

SIMPO HV is designed with no fixing parts between modules to save the space. Instead, limited fixing parts for fixing the system to the wall is designed to avoid the system from leaning or even collapsing. Each module and BMS can be used to install the fixing part. **Every three modules** stacked up is recommended to be fixed by one fixing part. Holes on the wall are needed to install the fixing parts and fix the system.

Please check the table below to confirm the quantity and position of fixing parts needed.

Module Qty per Tower	Qty of fixing parts recommended	Position of module fixing parts
2	NONE	NONE
3	1	③
4	1	④
5	2	③ & ⑤
6	2	③ & ⑥
7	2	③ & ⑦
8	3	③ & ⑥ & ⑧
9	3	③ & ⑥ & ⑨

AWG	External Diameter mm	Current A	Maximum Current A	Cross Sectional Area(CSA) mm ²
8	3.26	33.025	37.657	8.37
9	2.91	26.175	29.846	6.63
10	2.59	20.767	23.680	5.26
11	2.3	16.453	18.761	4.17
12	2.05	13.957	14.889	3.332

5.5 Power Cables Crimping

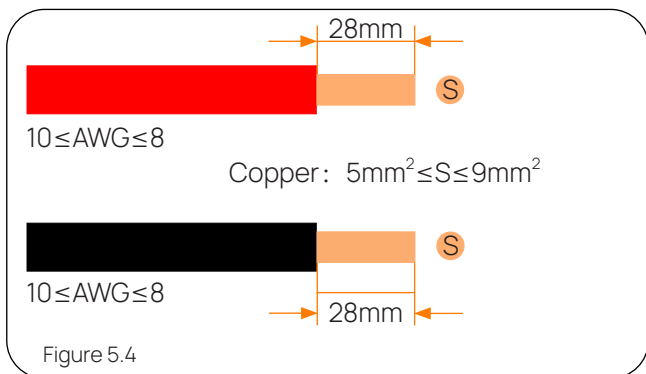

*Cables of 8/10 AWG is recommended to meet the need of SIMPO HV.
 *Determine the cable size according to your system. Check the table below for proper cable size.

5.6 Fix To The Wall

Step 1:

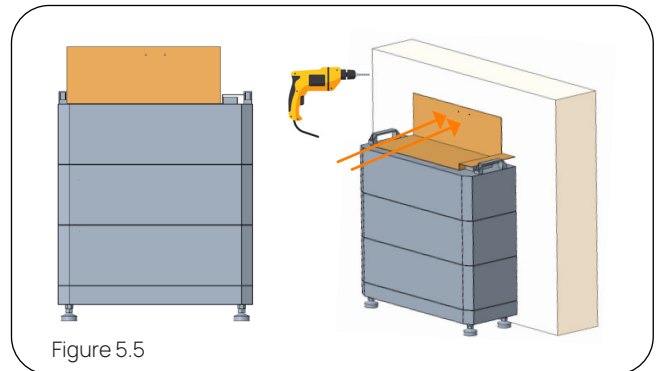

Before stacking up the module that needs to be fixed to the wall, use the stencil to locate the drilling holes and finish the drilling.

Step 2:

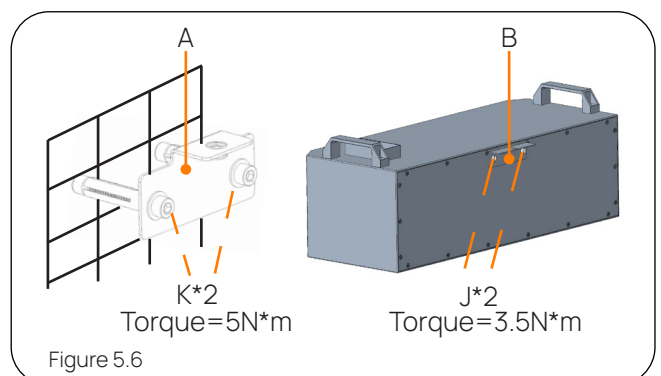

Install part A to the wall and part B to the module

Step 3:

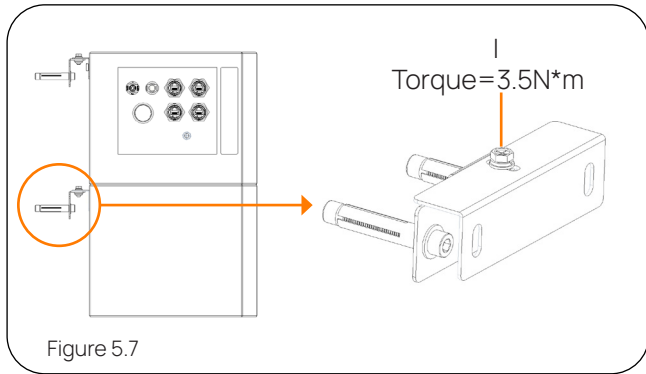

Stack up the modules and fix the screw I between part A and part B.
After stacking all the modules, the BMS is finally placed on top of the tower and fixed to the wall in the same way.

5.7 Cables Connection

System overview:

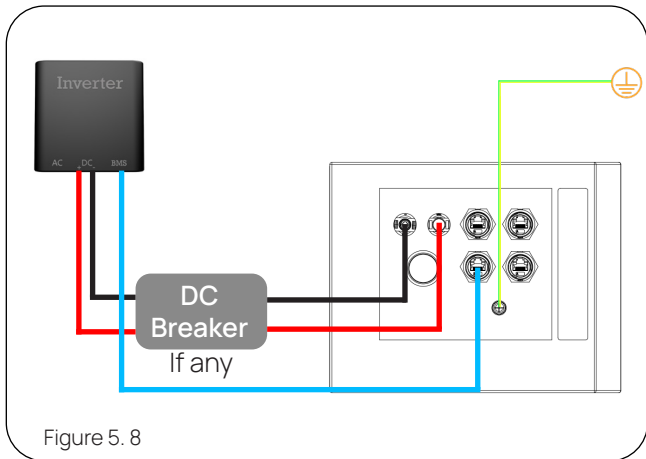

Connect the PE cables:

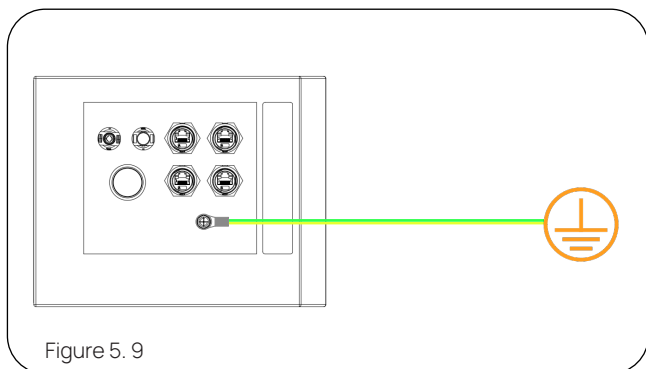

SIMPO HV is a high voltage product with minimum of 128V. Improper operation may lead to serious safety problems, before you start connecting power cables, make sure that the PE cable has been properly connected.

The torque for fixing the PE cable is 5N-m.

Please see '4.1 Extra Accessories' for PE cable size.

Connect the Power cables:

Battery side:

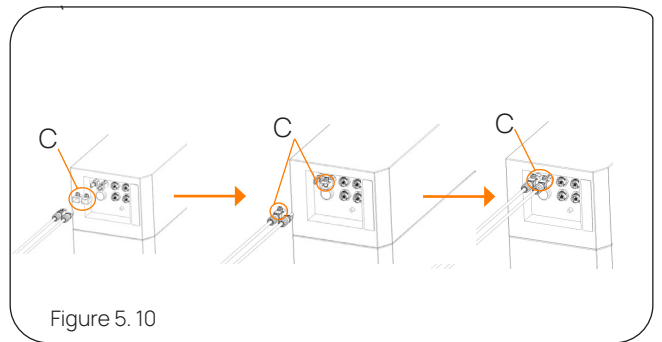

Use two Part C to fix the power cable on battery side. Install Part C on both female connectors, then wire both power cables through Part C and fix them.

Inverter side:

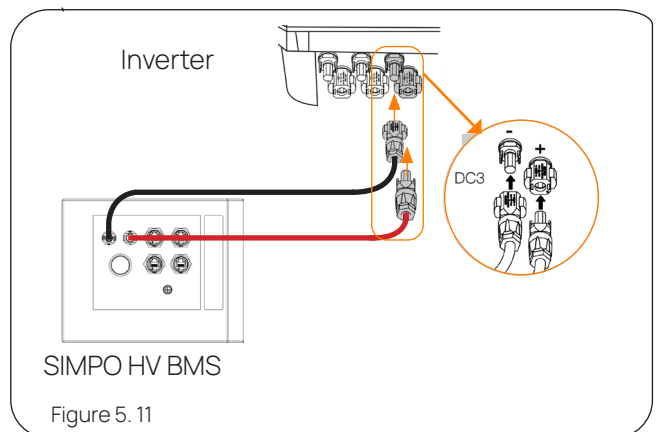

After finish the connection of battery side, connect the power cables to the inverter.

Connect the Communication Cable:

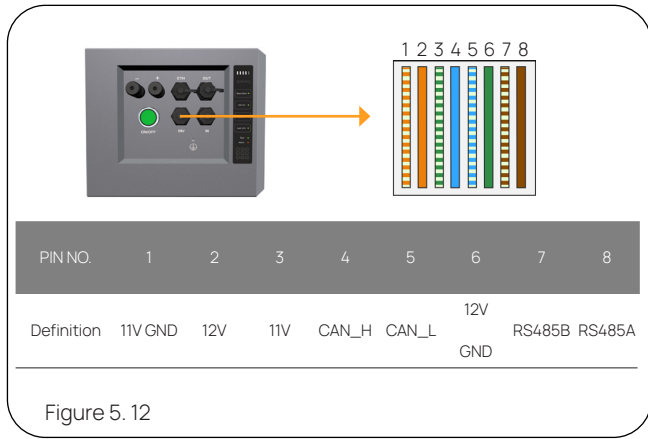

Figure 5. 12

Table on top is the Pin Number and definition of 'INV' port of SIMPO HV. Please check this table and the installation guide of inverter in use then change the cable order to complete the communication connection.

5.8 Communication With Different Inverter Models

For different models of inverters, the pin definitions of the communication cable are different, before connecting the communication cable, please match the pin definitions of SIMPO HV with inverter.

Connecting with Solis S6-EH3P & RHI

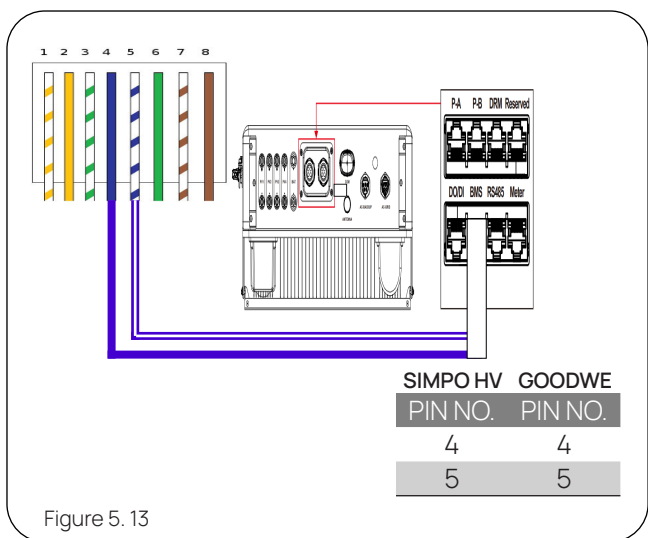

Figure 5. 13

Lead the communication cable through the COM1 or COM2 port of the inverter and connect to the BMS terminal.

Connecting with Kostal Plenticore Plus G2/ Plenticore G3/ Plenticore BI G2

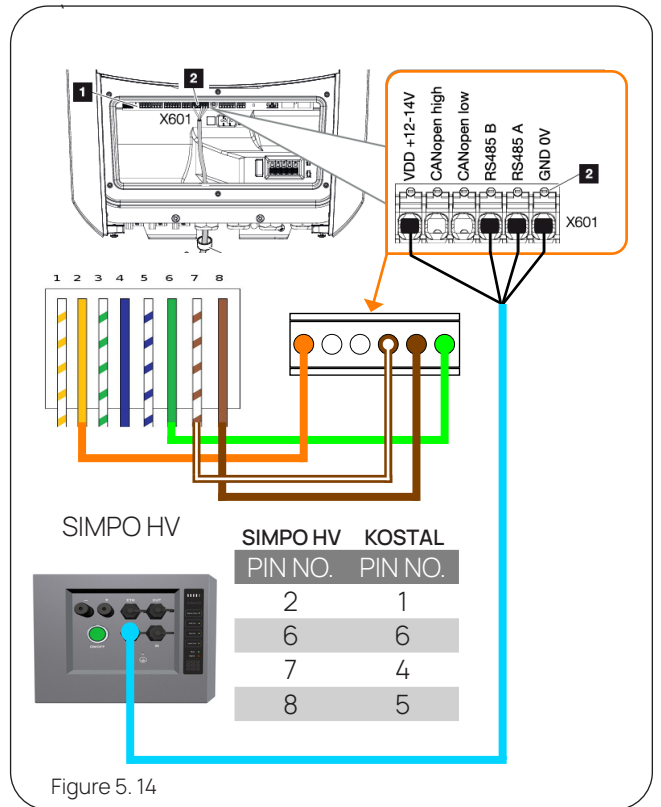

Figure 5. 14

Connecting with GOODWE Inverters

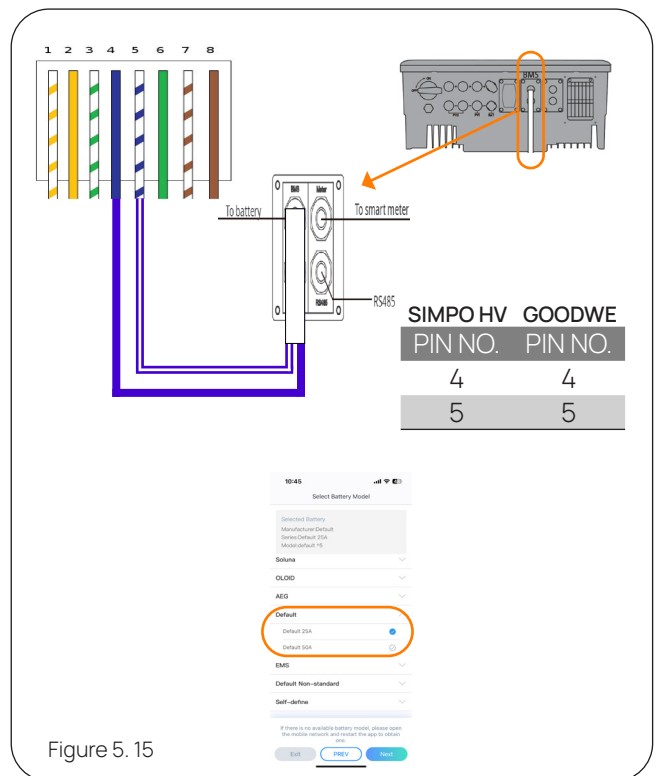
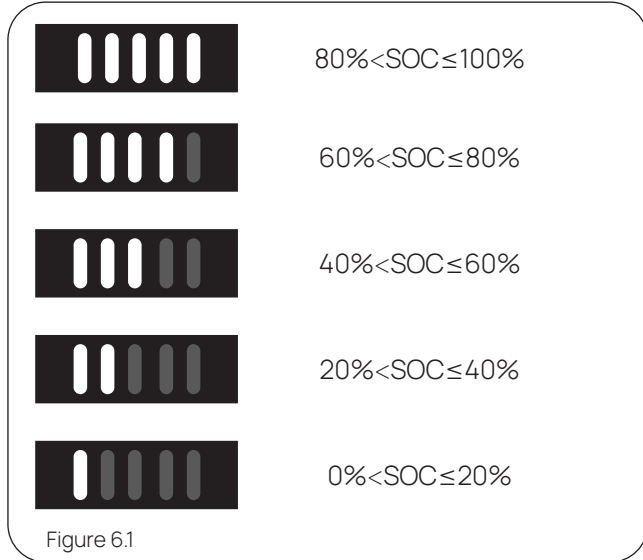

Figure 5. 15

When connecting with GoodWe Inverter, please select 'Default 25A' when selecting 'Battery model'.

6 Human Machine Interface(HMI)

6.1 SOC Status



The SOC status indicator visually displays the current SOC of the system. Each LED can represent 20% of the battery's energy.

While discharging, the last LED in the lit state will flash rapidly (once per second).

While charging, the last LED in the lit state will flash slowly (once every 2 seconds).

6.2 Black Start

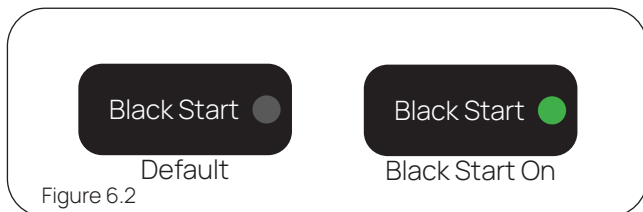

Black Start is a function specially designed for off-grid systems by ZYC Energy. In off-grid scenarios, SIMPO HV can supply energy to the inverter to start up the system by pressing the 'Black Start' button. Once the inverter starts working, the black start function will automatically terminate and the LED goes out as default.

6.3 WIFI On

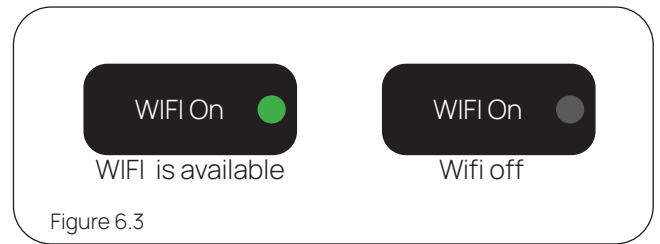

For SIMPO HV BMS, there is a Wifi module inside, and its wifi function can be turned on or off via the 'WIFI On' button on the HMI interface. When the wifi function is on, the LED indicator has three different status.

1. System is connected to the Internet: Flash slowly
 2. System is connected to mobile devices: Flash normally.
 3. Not connected to any device or internet: Solid On
- When the LED is off, the wifi function of SIMPO HV is off.

6.4 Set On

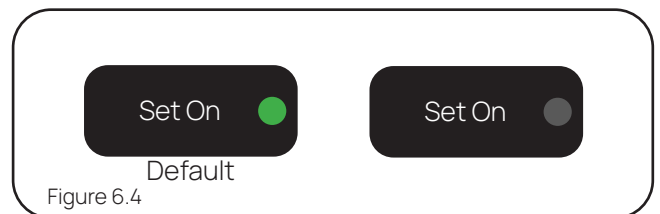

Set On is designed to confirm the Master tower (Tower that is directly connected to the inverter) in the system.

All 'Set On' LED are initially on. Although the system can still work when all towers' 'Set on' LED is on, it is recommended that you keep only the master tower's 'Set on' LED on.

6.5 Last Unit

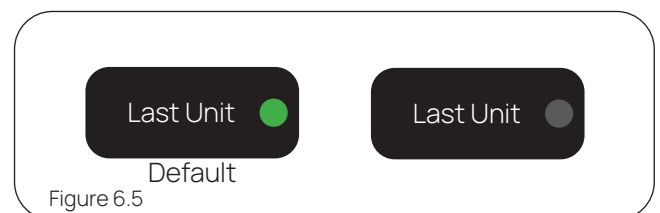

'Last Unit' is designed to confirm the last tower in the system and to complete the communication connection. By default all 'Last Unit' LED are solid on.

Unlike 'Set On', there should be only one tower that is set to be the last tower, otherwise the communication circuit can not complete.

Press the 'Last Unit' button on each tower and see the LED off except the last tower.connection. By default all 'Last Unit' LED are solid on.

Unlike 'Set On', there should be only one tower that is set to be the last tower, otherwise the communication circuit can not complete.

Press the 'Last Unit' button on each tower and see the LED off except the last tower.

6.6 Run



When the system is working normally, 'Run' will light up green. When the system is not working, 'Run' will be off.

6.7 Alarm

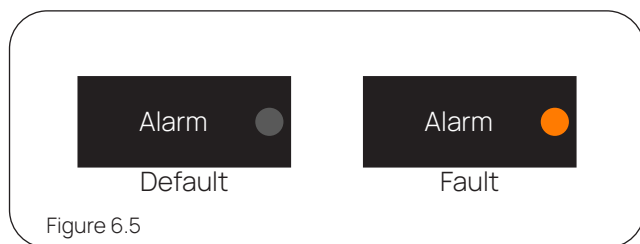

When the system is working normally, 'Alarm' will keep off, and when serious fault (including over-voltage, over-current, etc) occurs, 'Alarm' will light up orange.

6.8 Module Status Indicator



This area shows the status of up to 9 modules in a single tower, numbers 1-9 corresponding the modules from top to bottom (Master to Slave N) in a single tower. When the module is working properly, the indicator LED is off, and any module fails, the corresponding number will light up orange.

7 Parallel Multiple Towers

System overview:

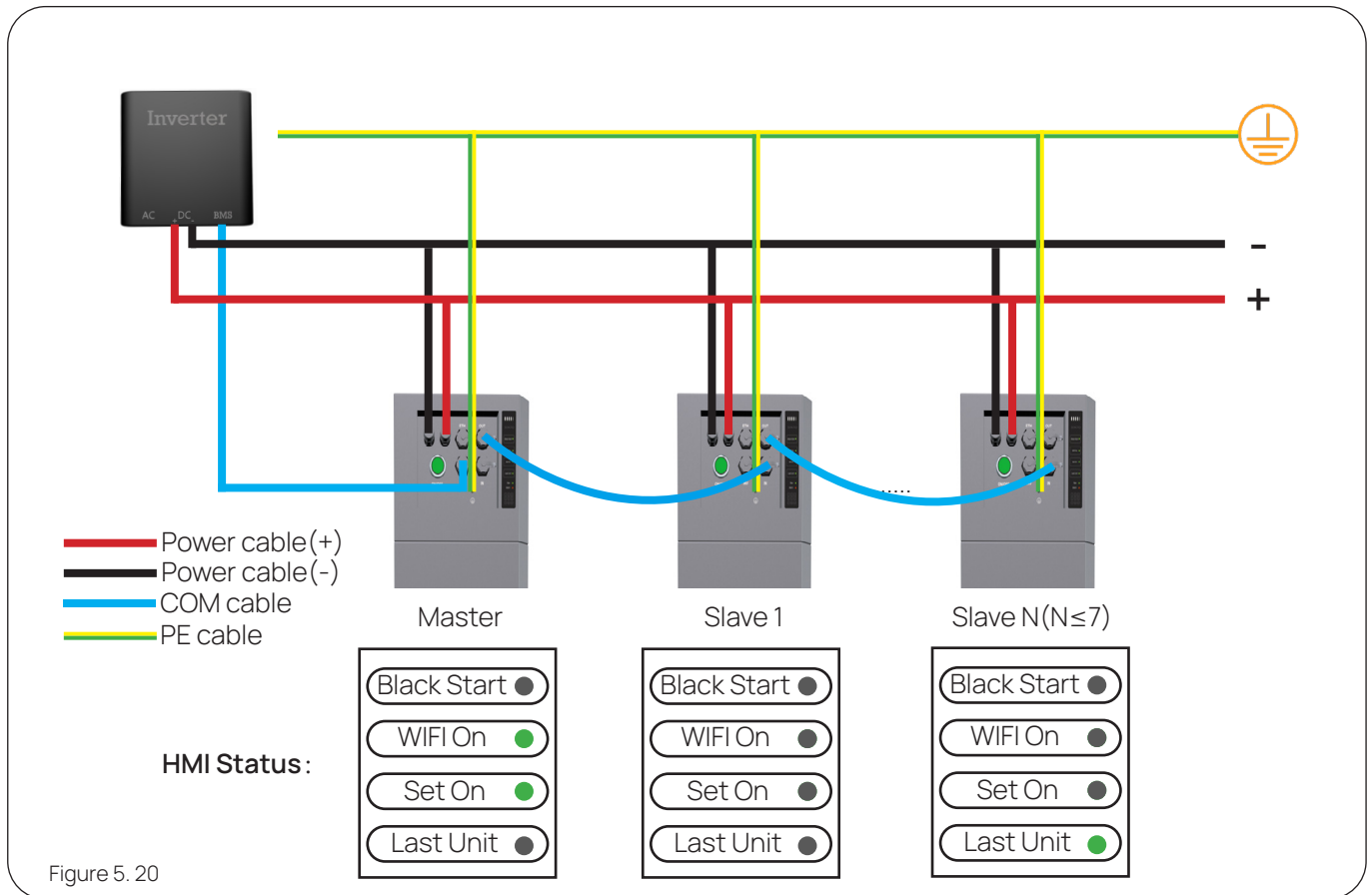

SIMPO HV allows up to 8 towers to be paralleled (1 master tower and 7 slave towers in the system). Up to 9 modules can be connected in series within one tower. To parallel multiple towers, please follow the steps below:

1. Ensure that the number of modules in the towers of the paralleled towers is equal, otherwise the paralleling will fail due to unbalancing voltage of the towers.
2. Connect the PE cable of each tower.
3. Connect the communication cables between towers (From the 'Out' port of the master tower to the 'In' port of Slave 1, then from the 'Out' port of Slave 1 to the 'In' port of next slave tower). Finally, connect the communication cable between the inverter and the master tower (from the 'INV' of the master tower to the inverter).
4. Connect the power cables of all towers to the busbar, then connect the busbar to the inverter. After finishing the above operations, you can turn on the air switches of all towers, then press the 'On/OFF' button of the master tower to start the whole system and check the HMI status of each tower. The 'Set On' on the main tower should remain on and the 'Last Unit' should remain off. The 'Set On' on the last tower in parallel should remain off and the 'Last Unit' on the last tower should remain on. The 'Set On' and the 'Last Unit' on the remaining towers should remain off.
5. All the 'WIFI On' on slave towers will be off automatically after the system starts for energy saving.

8. Commissioning

8.1 Air Switch



Figure 8.1

ZYC Energy has designed an air switch for each BMS to protect all modules in a single tower controlled by that bms. It is mounted on the side of the BMS. The air switch will automatically disconnect to protect the modules in the event of an overvoltage or overdischarging condition that could harm the modules. The air switch also protects the module when an internal failure occurs.

8.2 Start Up



Figure 8.2

Before start up the system, make sure that all PE and power cables and communication cables are properly connected. Then you can follow the steps below to start up the system:

- ① Turn on the DC breaker between the system and the inverter(if any).
- ② Turn on the Air Switch of each paralleled tower.
- ③ Press the '**ON/OFF**' button to start the system.

8.3 System Shut Down

Turning the system off is as easy as turning it on, follow these steps to shut down the system:

1. Turn off the inverter.
2. Turn off the DC breaker between the system and the inverter.
3. Press and hold the ON/OFF button for 3 seconds on the BMS.
4. Observe the LED on the HMI to make sure the system is off.
5. Turn off the Air Switch of each paralleled tower..

8.4 Charging and Discharging

Simpo HV is a very powerful battery, equipped with the latest low temperature technology. Making it not only able to discharge at $-20\text{ }^{\circ}\text{C}$, but also allows charging at $-10\text{ }^{\circ}\text{C}$. The charging temperature is recommended to be between $-10\text{ }^{\circ}\text{C}$ ~ $50\text{ }^{\circ}\text{C}$ and discharging temperature is between $-20\text{ }^{\circ}\text{C}$ ~ $50\text{ }^{\circ}\text{C}$. When discharging, SIMPO HV can provide a continuous current of 30A and a peak current of 45A for up to 5 seconds.

9 Connect to the Internet&ZYC portal&ZYC Assist

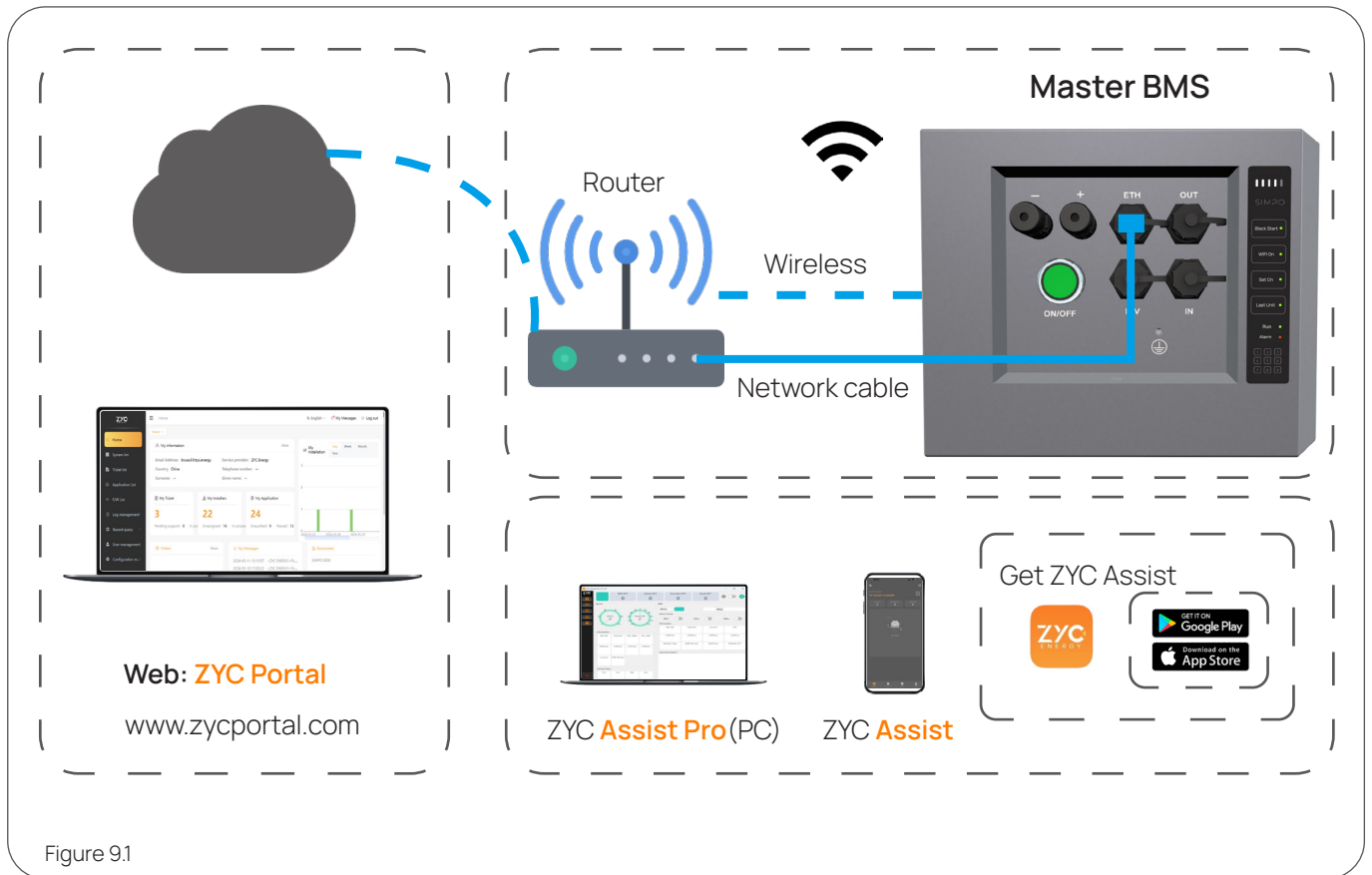

Figure 9.1

SIMPO HV BMS is equipped with a wifi module, so no additional components are required for remote monitoring. Three options are listed below to realize the remote monitoring.

1. Connect the ETH port on SIMPO HV BMS to the router via a network cable and link your system to the internet.
2. First make sure the wifi function is on, then use laptop or mobile phone to connect to SIMPO HV's WIFI hotspot, and monitor the system through ZYC Assist or ZYC Assist Pro.
3. After connecting the SIMPO HV hotspot, use ZYC Assist Pro to configure SIMPO HV to a nearby wireless network, and monitor the system on ZYC Portal remotely.

Note: For more details on ZYC Portal, ZYC Assist APP, please refer to 'User Manual of ZYC Tools_V1.1_EN'.

Download ZYC Assist App

ZYC Assist is now available at App Store and Google Play.

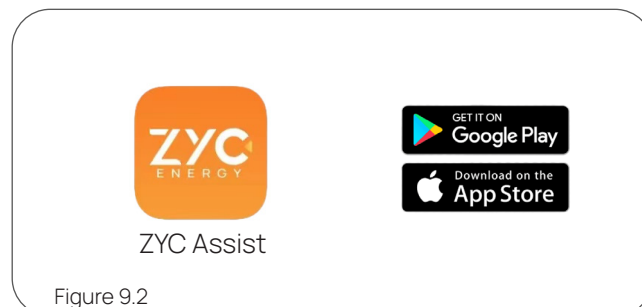
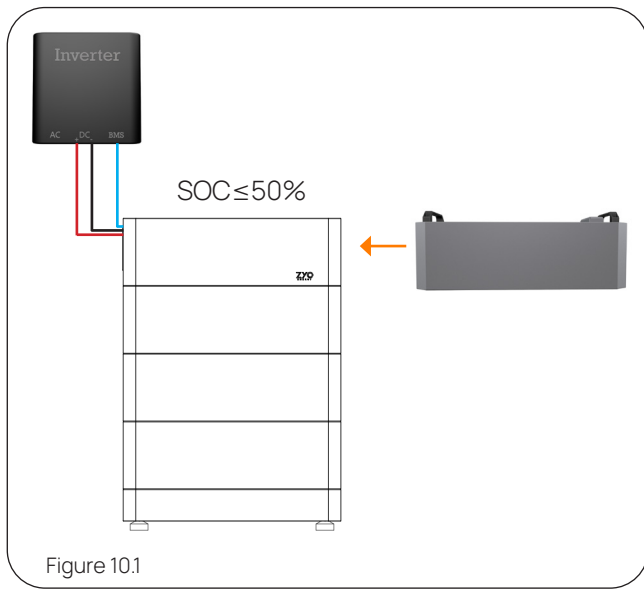

Figure 9.2

For more details of using ZYC Assist, please refer to *User Guideline of ZYC Assists*.

10 Expansion

SIMPO HV supports capacity expansion throughout the entire lifecycle. Advanced balancing technology provides seamless and efficient support for system balancing. For optimal performance, it is advised to expand the system when the SOC is under **50%**, ensuring quicker balancing



Follow the steps below to expand the system:

- ① Turn off the inverter.
- ② Turn off the system.
- ③ Turn off all the DC breaker (if any) and the air switch.
- ④ Remove the BMS and stack up the new module.
- ⑤ Turn on the DC breaker (if any) and the air switch.
- ⑥ Turn on the system.
- ⑦ Turn on the inverter.

11 Troubleshooting

Please refer to *Service Guideline*.

12 Maintenance and Storage

Maintenance

operator: Maintenance can be done by the end user or installer.

Inspection period: Every year

Battery Condition Inspection: Regularly check the appearance of the battery for deformation, bulging,

leakage or burn marks.

Wiring condition: Make sure the battery connection terminals are not loose, corroded or overheated.

Environment check: Ensure that the indoor temperature and humidity meet the requirements. Check whether the ventilation system is functioning properly to avoid gas accumulation.

Battery Performance Test: Check for proper voltage, current, SOC, and any fault alarms.

Software and Firmware Updates: Check and update BMS and monitoring software to improve management efficiency and safety.

Cleaning:

SIMPO HV is recommended to be cleaned once each month. If there is dust or stains on the enclosure of SIMPO HV, use a brush or soft towel or to wipe the enclosure to remove the dust. Do not use any corrosive solution or stuff that may damage the battery to clean the enclosure.

Storage

SIMPO HV should be stored at the range of -10°C to 50°C and charged every 6 months. When periodically charging the battery, use no higher than 0.5C to charge the battery to 30% SOC. However, as part of your overall system maintenance, some checks can be carried out at least yearly.

- Check Status LED.
- Check battery connections and cables for secure fitting or damage.
- Check for any obstruction placed around the battery or battery enclosure.
- Check for animals, insects or creatures nesting in or around the battery enclosure.
- Check for build-up of any foreign objects around the modules.

13 Disposal of SIMPO HV

When disposing of discarded SIMPO HV, observe local regulations for the disposal of electronic waste and used batteries. And observe the following requirements:

- Do not dispose of SIMPO HV together with household waste.
- Do not leave the waste batteries in direct sunlight or high temperature.
- Do not dispose of used batteries in high humidity or corrosive environments.

14 Compatible Inverter

Please refer to *SIMPO HV Inverters Compatibility List_ V1.2*

15 Date of Manufacture

To get information related to the date of manufacture of the product, find the serial number on the nameplate of the product, always in format as below:

ZS011B10A0**240223**000001

24: Years, here means year 2024

02: Month, here means February

23: Day, here means 23th.

The bolded number indicates the date of manufacture of the product.

16 Warranty

Please note, to avoid the impact of warranty, the product should be installed within **one month** of purchase date.

For more information about the warranty, please visit **ZYC Portal on www.zyc.energy** and find the Warranty Letter

17 Contact Us



ZYC Energy Australia Pty Ltd



Suite 37 Ridge St North Sydney NSW 2060, Australia



+61 2 8006 1868



service@zyc-energy.com.au



ZYC Lithium Batteries S.L.



Calle Angelita Caverro 13 Oficina 4 Madrid (28027), Madrid, España



+34 6 97919475 / +49 7119987199



service@zyc.energy



ZYC Energy Company Limited



GuangKe Road 1, Pingshan, Shenzhen, P.R. China



+86 (0) 755 2839 4019



service@zyc.energy



WhatsApp: +86 19168831702



www.zyc.energy